

BACKSCATTER HYBRID FLASH

UNDERWATER STROBE + LIGHT



THE ULTIMATE STROBE AND VIDEO LIGHT

DOWNLOAD
INSTRUCTIONAL
VIDEO



WARNING
NEVER TRAVEL WITH BATTERIES INSTALLED

INCLUDED ITEMS

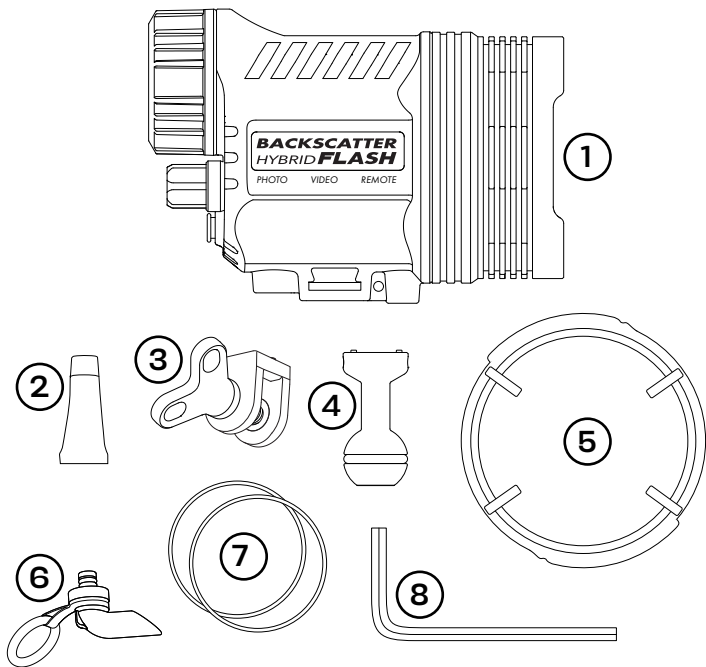

1. Backscatter Hybrid Flash Strobe
2. O-ring Grease
3. YS Mount
4. 1-inch Ball Mount with Bolt & Washers
5. Flat White Diffuser*
6. Light Pipe (for remote operation)
7. Spare O-rings (2)
8. $\frac{3}{16}$ -inch Hex Wrench

**BATTERIES AND
CHARGER SOLD
SEPERATELY**

**Installed on Strobe*

NAME OF PARTS

REAR VIEW

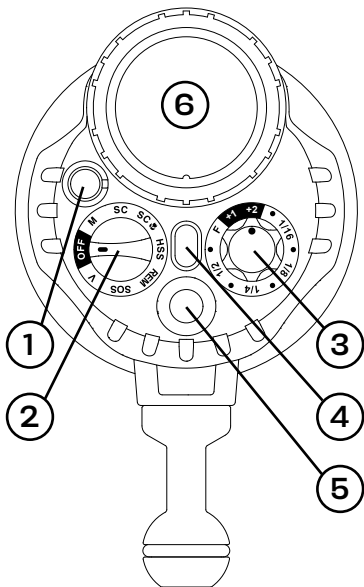

BOTTOM VIEW

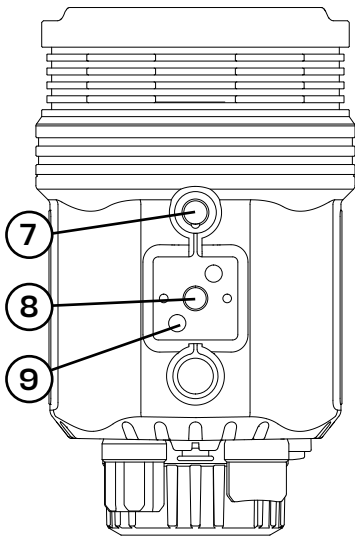

1. Test Button & Indicator Light
2. Mode Dial
3. Power Intensity Knob
4. Main Indicator Light
5. LED Light Mode Button

6. Battery Compartment
7. Fiber Optic Port
8. $\frac{1}{4}$ -20 Inch Mounting Point
9. Mounting Alignment Points

BATTERY & O-RINGS

BE SURE TO READ THE FULL BATTERY FAQ AND SAFETY INSTRUCTIONS AT THE END OF THIS MANUAL

ONLY USE APPROVED BATTERIES: We recommend Nitecore 21700 NL2153HP 5300mAh batteries. Batteries are available from Backscatter or Backscatter Authorized Dealers and other retailers worldwide.

WARNING! NEVER USE AN UNAPPROVED 21700 BATTERY!

To install a battery, twist off the battery cap, remove the double O-rings, and clean the O-rings and the grooves on the battery compartment. Lightly grease the o-rings with the provided o-ring grease and re-install the o-rings on the battery compartment.

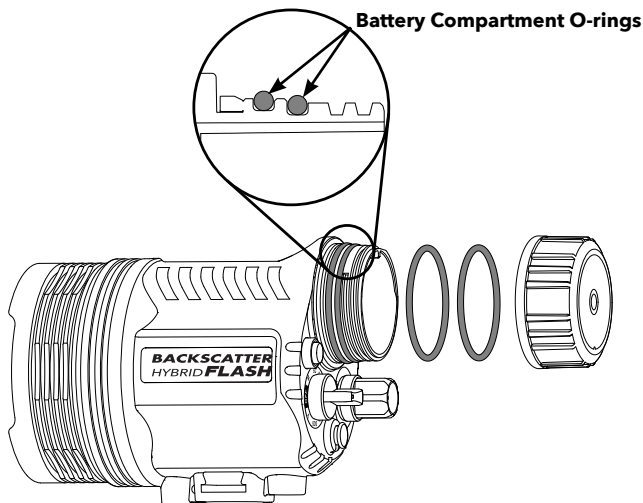

Note: Using batteries with less than 15A continuous discharge current will cause the batteries to shut down, and the Hybrid Flash will not operate.

Install the approved 21700 batteries in the battery compartment according to the diagram. Inspect and clean the battery cap O-ring sealing surface, then line up the notches in the battery cap with the battery cap alignment rails in the light body and twist the battery cap into place.

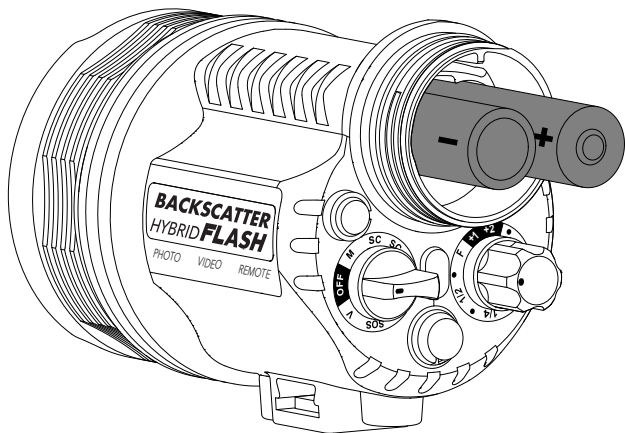

Verify you have fully twisted the battery compartment until it stops.

WARNING! IF YOU SEE WATER INTRUSION OR CORROSION IN THE BATTERY COMPARTMENT OR THE STROBE BODY, STOP USE IMMEDIATELY AND CONTACT US.

Never attempt to open the front part of the strobe in an effort to service the Hybrid Strobe yourself. Return the strobe for service to an Authorized Backscatter Dealer for servicing needs. The Hybrid Flash has very high voltage capacitors that hold a charge long after the strobe has been powered off that can cause an electrical shock during unauthorized servicing that can lead to severe injury or death to an untrained service technician.

NEVER CHARGE BATTERIES UNATTENDED: Never go to sleep or leave charging batteries unattended. Lithium battery charging could be deadly if the proper precautions are not taken.

FIBER OPTIC CABLE

The Hybrid Flash is compatible with any angled end style fiber optic cable. Plug one end of the cable into the Hybrid Flash and the other end into the fiber optic adapter of the camera housing.

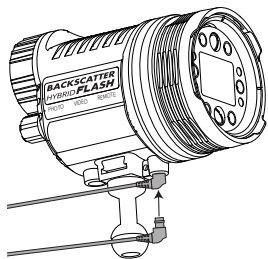

MOUNTING OPTIONS

Choose the ball mount for standard 1-inch aluminum ball arms and install with the included hex wrench. Choose the YS mount for use with ball arm adapters that have a YS mount on one end. Due to the weight and size of the Hybrid Flash, it is not recommend to be mounted with flex arms.

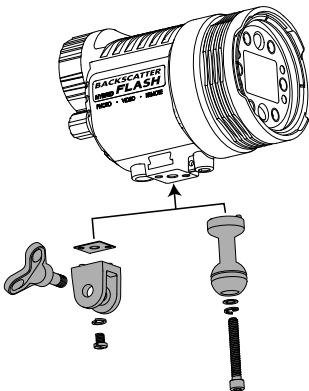

AUTO STANDBY (15 MINUTES)

When the LED Focus Light is off, and the Hybrid Flash has not fired for more than 15 minutes, it will enter stand-by mode to conserve battery power. To exit Stand-by mode and resume normal operation, activate any control or fire a flash with the camera.

AUTO-OFF SAFETY (2 HOURS)

The Hybrid Flash will automatically power off when inactive for more than 2 hours. Wake-up the Hybrid Flash by cycling the mode dial off and on.

LED LIGHTING MODES

The Hybrid Flash has 3 different modes for the LED lights: Snoot, Wide, and Red. The lumen output will be determined by whether the Hybrid Flash is in one of the Photo modes (flash active) or the Video mode (flash inactive).

In photo mode, the wide LEDs are limited to 2000 lumens. In video mode, the output is 5000 lumens.

Note: When switching from Video Mode to one of the photo modes, the time for the flash to charge to full power may be longer for the first shot after switching from Video to a Photo Mode.

To change LED light mode: Snoot, Wide, and Red.

Press and hold the Mode button for 2 seconds to change the mode.

To change LED power level output.

Press and quickly release the Mode button to toggle between 3 different power levels and off. As the battery is depleted brightness level options will decrease from 3 to 2, and finally a low safety power level. Battery levels are managed to allow for over 90 minutes of total run time.

OPTICAL SNOOT WHAT YOU SEE IS WHAT YOU GET

The Hybrid Flash packs plenty of punch when it comes to using the optional Backscatter Optical Snoot and aiming the snoot has never been easier. We recommend power level low or medium on the target light for most situations, but full power level will help your aim even in the brightest shallow water conditions.

Note: The Snoot LED light mode is designed and optimized for use with the Backscatter OS-2H Optical Snoot to allow the brightest transmission of light aiming through the snoot. The spot target light is primarily designed to work with the OS-2H optical snoot, but can also be used as a target light for up close macro use. The Red beam may also be used with the snoot.

The Wide LEDs are meant to be used without the snoot installed, are not designed to work with the snoot and, will result in a lower brightness snoot target light compared to using the Snoot LED mode.

THERMAL PROTECTION DESIGNED TO KEEP YOU SHOOTING

Due to the very high guide number and resulting heat when firing at maximum power level, the Hybrid Flash contains multiple safeguards to prevent damage due to over flashing or heat build up when set to power levels F, +1, and +2. At lower power levels heat buildup is dissipated quickly and will not lead to an overheating condition.

When an overheating temperature threshold is reached, the Hybrid Flash will emit a long beep and the Main Indicator Light will flash purple. This will occur when shooting at the maximum GN 40 rapidly in continuous succession for an approximately sustained 35-55 shots as fast as the Hybrid Flash can recycle, depending on environmental conditions and previous retained heat. At this point the Hybrid Flash will reduce the flash output by 1/2 stop and allow the photographer to keep shooting. If shooting continues rapidly in a continuous succession the Hybrid flash will reduce the flash output by another 1/2 stop and allow the photographer to keep shooting. When the Hybrid Flash is in a heat protection mode if it is again fired repetitively 25 times within 2 minutes the flash will suspend firing for 2 minutes for a cooling down period after which the Hybrid Flash will resume firing. The Hybrid Flash gives the overheating warning very far in advance of reaching the point of where it needs this mandatory 2 minute cool down, giving you the shooter control over how to manage thermal buildup.

The reality of shooting at the higher power levels of the flash is that most shooters will never reach the thermal protection modes as it only occurs after sustained rapid shooting at the highest power levels for an extended

number of shots immediately in a row. If the thermal protection mode is reached all it takes is a brief pause to allow the strobe to cool off to exit the thermal protection mode, sometimes just 10-20 seconds. If the action is going off and more shots are necessary the strobe will lower its power output automatically, or as the shooter you can lower the power yourself to get the most amount of shots when the action requires it.

Our philosophy is a slightly lower amount of light is better than no light and we designed this strobe to provide the most amount of shots possible while trying to manage the rare occasion of heat buildup.

This is why the power levels are labeled F, +1, and +2 as a means to alert the user that these power levels have some modest restrictions for rapid fire shooting and the resulting heat buildup.

So in other words, don't worry about it too much! The Hybrid Flash has your back when you need to keep shooting for that epic ephemeral scene.

BACKSCATTER SONY TTL FLASH TRIGGER AUTOMATIC FLASH EXPOSURE

The Backscatter Sony TTL Flash trigger is a LED flash trigger that allows for manual, TTL, and HSS operation when used with the Hybrid Flash. It is also compatible with other strobe brands for manual flash firing and is additionally compatible with Retra strobes in HSS mode.

The TTL protocol of the Backscatter Sony TTL Flash trigger is proprietary and is only compatible with the Hybrid Flash. It is not compatible with other strobes that have a TTL system designed for fiber optic cables.

There are certain camera menu settings that must be used for operation of TTL and manual flash operation. Please see the sections of this manual for Manual flash mode (page 12) and Smart Control (SC) modes (page 14) for specific instructions on setting the camera menu for using the Backscatter Sony TTL Flash trigger with the Hybrid Flash.

The Backscatter Sony TTL Flash trigger is an optional accessory available separately.

DIFFUSERS WIDEN THE FLASH BEAM & SELECT A COLOR TEMPERATURE

Diffusers modify the flash beam pattern by spreading the beam wider and making it more even with softer edges. There are both flat and dome diffusers available for the Hybrid Flash in various color temperatures, giving the photographer complete control over beam width and color. The Hybrid Flash comes with the flat white diffuser, the other diffusers are optional accessories.

The Flat diffusers expand the native 120 degree beam pattern of the Hybrid Flash out to 140 degrees. Dome diffusers will expand the coverage to 160 degrees. In lower visibility conditions with a lot of scatter in the water, the flat diffuser is preferred because it is slightly more directional in its coverage with the narrower beam pattern which makes it easier to eliminate scatter in the shot with proper strobe positioning. The dome diffuser provides an edge to edge even beam but is a little harder to eliminate scatter in the corners with a fisheye lens in low visibility conditions. Flat diffusers are more forgiving for eliminating scatter in low vis, and the domes are very forgiving for strobe positioning in clear water due to the evenness and width of the beam, and is the best choice for very large scenes.

Diffusers are available in 4 colors: White (6300K), 5500K, 4500K, and Ambient. The white diffusers at the higher color temperature of 6300K are a good all around choice and will have a further reach into a scene due to its higher color temperature than the warmer varieties. It is recommended to use Auto White Balance on the camera with the white diffusers.

The 5500K warming diffusers are a very popular color choice among photographers who are looking for a more “faithful” daylight look underwater and are perfect for model shoots, providing warmer, more saturated skin tones for human subjects. The 4500K warming diffusers work well to turn greenish/aqua water more blue, especially in lower visibility conditions. In clear shallow waters it will help the hue of the water turn more blue and give an appearance of the shot looking like it was shot at a deeper depth than it was. When using these diffusers it is recommended to set the camera’s white balance setting to 5500K or 4500K, respectively.

The Ambient diffusers take a completely different approach and are designed to match the cooler color temperature of the water. With the Ambient diffusers the strobe light is the same color as the surrounding water and is now just filling shadows as with a land shot with a flash where the flash and ambient light are the same color. This will give a more natural even look to photos and the light will have the most penetration into the scene. The Ambient diffusers work best in a depth range of 10-35 feet. It is recommended to execute a custom white balance with the Ambient filters installed on the strobe to get the correct color balance.

For more information how to use the different diffusers and the selectable color temperatures, check out all of our instructional videos and articles on the Backscatter website using the QR code on the front cover of this manual.

To Install a Diffuser:

1. Line up the unlock icon of the diffuser with the white dot on the bottom of the front bezel of the Hybrid Flash.
2. Turn the diffuser towards the lock icon and click into place.
3. It is recommended to use the included lanyard to safely keep the diffuser attached to the strobe body during installation and removal to help prevent it from loss to the abyss.

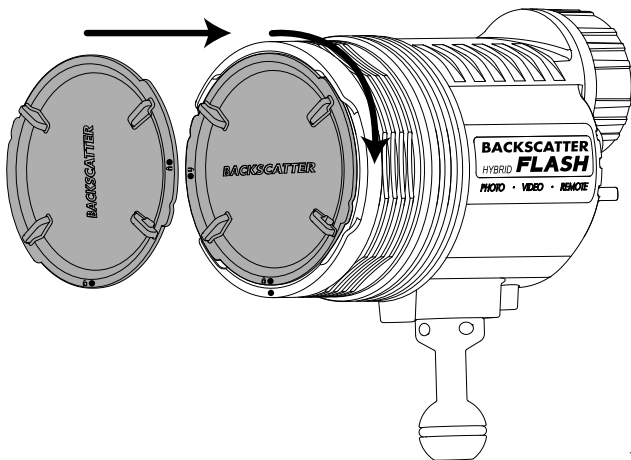

MODE MANUAL (MOST POPULAR)

This is the recommended primary mode for most shooters.

Learning Mode for Pre-Flash Cancellation

The Hybrid Flash will learn the camera's pre-flash or manual flash pattern on the first flash that is fired after turning on the Hybrid Flash to the M position.

1. Starting from the OFF position, turn the black mode dial to "M" for Manual mode
2. Take a photo with the camera. The Hybrid Flash will automatically learn whether the camera is set to single flash or preflash and learn the camera's or flash trigger's preflash pattern. **Do not use continuous shooting when taking this shot**, as this could cause the Hybrid Flash to take a false reading, resulting in shots that are not synchronized between the flash and the shutter.
3. Repeat this process anytime the flash has been turned off.

Adjusting the Power Level Dial

The red dial adjusts the power output. There are 12 levels of manual power control in 1/2 stop increments. The maximum power level is +2.

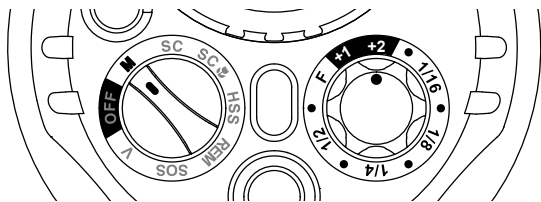

How to Turn Off Learning Mode for Manual Trigger/Flash Users

For shooters who use manual flash triggers or an internal camera flash in manual mode that only emit 1 flash, learning mode can be disabled so the default when powering on the strobe is to fire on the first flash that occurs rather than having to teach the Hybrid Flash each time it is powered on.

Note: If using a manual flash trigger or internal flash, especially with continuous shooting, it is highly recommended to turn off learning mode.

To Turn Off Learning Mode

1. Make sure the flash is off and batteries are installed.
2. Press and hold the Mode button.
3. While keeping the mode button held down, turn the power dial to M and keep holding the Mode button down until the Main indicator light and Test light both blink, approximately 5 seconds, then release. The default blinking color is blue, which is Learning Mode ON.
4. Press the mode button to toggle between Learning Mode ON and Learning Mode OFF. Learning Mode OFF will be indicated by a green blinking light.
5. After the selection is made, press the TEST button to confirm. The strobe will then exit the Learning Mode menu and is ready to fire.
6. This setting will stay in the memory of the Hybrid Flash until it is changed again in the Learning Mode menu.

Note: With preflash cancellation learning mode set to OFF, the flash will fire on the first flash it sees, which is the typical setting for manual flash triggers and manual internal flash settings.

Pro Tip: If your camera allows, set the internal flash to manual with a low power level. This will enable the camera to fire faster and use less camera battery than in fill-in flash mode.

Menu Settings for Sony with the Backscatter Sony TTL Flash Trigger For Manual Flash Operation in M mode

1. Go to Camera Menu → Flash → Wireless Flash ON.

Note: The Hybrid Flash must be set in M mode to fire manually. It will not fire in either SC mode when the flash trigger is set to manual operation (Wireless Flash ON).

Pro Tip: Assign the Wireless Flash menu setting to a custom button to toggle between Wireless Flash OFF and ON to quickly switch the TTL and manual operation of the flash trigger .

MODE SMART CONTROL (SC & SC) AUTOMATIC FLASH (TTL) OLYMPUS, OM & SONY

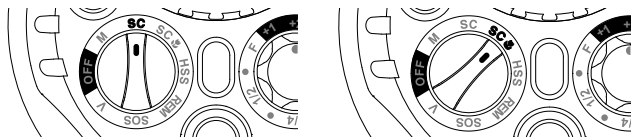

Smart Control modes (SC and SC ) provide very accurate automatic TTL exposures with Olympus/OM and Sony cameras. Follow the instructions below to select the best SC mode and to properly configure the camera menu settings.



SC Mode

Select SC Mode for automatic TTL exposure of larger subjects such as fish portraits, turtles, and reef scenes.

SC Mode

Select SC  Mode for more accurate automatic TTL exposures of small macro subjects close to the camera. For Olympus/OM TG cameras, use SC  mode when in Microscope mode or AF Super Macro. For mirrorless cameras, use this mode when shooting close-up macro (such as subjects smaller than a golf ball), especially with wider apertures.

Note: TTL flash compensation is controlled by the camera in the camera's flash compensation menu.

LISTEN FOR MINIMUM AND MAXIMUM EXPOSURE WARNING BEEP:

The strobe will sound a warning beep to alert you that the flash has fired at maximum output or if the minimum power is too bright for the scene. If the resulting image is too dark, get closer, increase ISO, open the aperture, or combine all three to get the strobe back into a usable range. If the image is too bright, decrease ISO or close the aperture to get the strobe back into a usable range.

Note: The factory default setting for the SC Mode camera brand is for Olympus/OM System. If you are using an Olympus/OM System camera, no setting change is required out of the box.

Selecting the Camera Brand for SC Mode

1. Make sure the flash is off and batteries are installed.
2. Press and hold the Mode button.
3. While keeping the mode button held down, turn the power dial to SC and keep holding the Mode button down until the Main indicator light and Test light both blink, approximately 5 seconds, then release. Follow the specific instructions below for your particular camera brand.

To Select Olympus/OM

1. Short press the mode button until both indicator lights are blue.
2. After the selection is made, press the Test button to confirm the selection. The strobe will then exit the SC camera brand selection menu and is ready to fire. When in SC mode the Test indicator light will show blue to confirm the Hybrid Flash is in the Olympus/OM SC mode.

To Select Sony

1. Short press the mode button until both indicator lights are white. A second selection needs to be made depending on the camera model being used.
2. Turn the red power level dial to the +2 position for all Sony camera models with the exception of the a7R V.
3. For the a7R V, turn the red mode dial to the +1 position.
4. After the selection is made, press the Test button to confirm the selection. The strobe will then exit the SC camera brand selection menu and is ready to fire. When in SC mode the Test indicator light will show white to confirm the Hybrid Flash is in the Sony SC mode.

Note: The camera selection settings only need to be done one time and will stay in the memory of the Hybrid Flash until it is changed again.

MODE SMART CONTROL (SC & SC 🌱) AUTOMATIC FLASH (TTL) OLYMPUS, OM & SONY (CONT.)

Required Camera Menu Settings for Olympus/OM in SC and SC 🌱 Modes

SC and SC 🌱 modes on the Hybrid Flash requires the camera be set to RC mode. Most cameras do not have RC mode turned on by default. Select your camera from the setting guides below.

Required Camera Settings for Olympus TG-1 to TG-4 Cameras:

1. Go to Camera Menu → Accessory Settings → Remote Flash → RC, then exit menu.
2. Then, press the flash icon button on the 4-way control and set the flash to RC.

Required Camera Settings for Olympus/OM TG-5 to TG-7 Cameras:

1. Press the flash icon button on the 4-way control and set the flash to RC.

Required Camera Settings for Olympus/OM Mirrorless Cameras:

1. Go to Camera Menu → RC Mode ON, then exit Menu.
2. Press the OK button. If the RC menu does not initially pop up, press the INFO button to toggle the view to the RC menu.
3. The Hybrid Flash operates on Group A, Channel 1. Set the camera RC menu to TTL in group A.

Note: On some Olympus/OM mirrorless camera models, the flash sync speed is reduced to 1/160 in RC mode.

Note: For TTL to work, Olympus/OM mirrorless cameras must use the internal popup flash or a compatible RC flash trigger. TTL with the Hybrid Flash is only compatible with Olympus or OM Systems cameras and lenses.

Using the Backscatter Sony TTL Flash Trigger for TTL Operation

To use SC and SC  with Sony cameras to achieve TTL, the Backscatter Sony TTL Flash Trigger is required. There is a proprietary communication between the Backscatter Sony TTL Trigger and the Hybrid Flash for TTL and HSS commands. Other 3rd party TTL flash triggers are not compatible with the TTL protocol of the Hybrid Flash. The Backscatter Sony TTL Flash Trigger can also be used for manual flash application as well with the Hybrid Flash and other strobes.

Menu Settings for Sony with the Backscatter Sony TTL Flash Trigger for TTL and HSS Operation in SC Mode

1. Go to Camera Menu → Flash → Wireless Flash OFF.

Note: This is the default factory setting for Sony cameras. The Hybrid Flash must be set in SC or SC  mode to fire TTL. It will not fire in any other mode when the flash trigger is set to TTL operation (Wireless Flash OFF). See the section “Mode--Manual” (page 12) to learn about Manual operation with the Backscatter Sony TTL Flash trigger.

MODE SMART CONTROL (SC & SC)

SUPER FP/HSS FLASH

OLYMPUS, OM & SONY

Hybrid Flash SC and SC  modes also allow Olympus/OM and Sony mirrorless cameras to use Super FP (Olympus/OM) and HSS (Sony). Super FP and HSS mean the same thing, which is High Speed Sync. Super FP/HSS allows for flash photographs at shutter speeds faster than the camera's normal maximum sync speed, up to 1/8000. This allows for a wider open aperture while still maintaining a darker background. Super FP/HSS is not available on compact cameras, as compact cameras do not have mechanical shutters.

Note: Super FP/HSS reduces flash output compared to regular shooting. Only use it for close-up shooting. The flash will diminish the faster the shutter speed is set.

Note: The Hybrid Flash has one output power in HSS mode. Changing the shutter speed to dial in the flash exposure is the recommended method for altering the flash in the image.

Camera Settings for Super FP for Olympus Mirrorless Cameras in SC mode:

1. Make sure the camera is in RC mode and access the RC flash menu (see TTL for Olympus/OM mirrorless shooters for setup)
2. In the RC flash menu, change the flash icon to FP
3. Set the Group A flash mode to either TTL or M.

Camera Settings for HSS with Sony Mirrorless Cameras in SC Mode with the Backscatter Sony TTL Flash Trigger

1. Turn the mode dial on the Hybrid Flash to HSS.
2. Go to Camera Menu → Flash → set Wireless Flash to OFF.
3. Go to Camera Menu → Shutter/Silent → Shutter Type → set to Mechanical Shutter.

Additionally for Cameras with e-Front Curtain Shutter:

4. Go to Camera Menu → Shutter/Silent → e-Front Curtain Shut. → set to Off

Note: For HSS use, Sony cameras must have the Shutter type be mechanical and e-front curtain shutter (if offered as an option) must be off. If these menu settings are not made banding may appear in the image, which will worsen with faster shutter speeds. This setting is not specific to the Hybrid Flash, this is for any Sony camera being used with a HSS compatible flash. Please see your Sony camera instruction manual for more details.

Note: On the camera, the switch from normal operation to HSS is automatically handled by the flash trigger when the camera's shutter speed is set faster than the flash sync speed limit. The camera will indicate it is in HSS mode when the flash icon changes from a single lighting bolt flash icon to having HSS displayed next to the flash icon.

Note: The Hybrid Flash must be set in SC mode to fire when Wireless Flash is set to OFF. It will not fire in either M or HSS modes when the flash trigger is set to TTL operation (Wireless Flash OFF).

Pro Tip: If you primarily shoot in TTL flash mode it is recommended to use the SC mode (rather than HSS mode) on the Hybrid Flash to do HSS as there are no changes needed to switch from normal TTL operation to HSS operation.

For shooters who primarily shoot Manual flash, please see the section titled "Camera Settings for HSS with Sony Mirrorless Cameras in HSS Mode with the Backscatter Sony TTL Flash Trigger." (page 21)

MODE HIGH SPEED SYNC (HSS)

HSS allows the camera to shoot a flash at shutter speeds faster than the camera's max sync speed. This only applies to mirrorless and SLR cameras. Compact cameras do not have mechanical shutters and thus don't have an upper limit on flash sync speed. In HSS, the flash can sync with shutter speeds up to 1/8000, allowing for a wider open aperture while maintaining a darker background. A compatible flash trigger is required for HSS operation. Contact Backscatter or a Backscatter Authorized Dealer for information on the latest 3rd party compatible triggers. The Backscatter Sony TTL Flash trigger set to manual flash mode is compatible with the HSS mode of the Hybrid Flash.

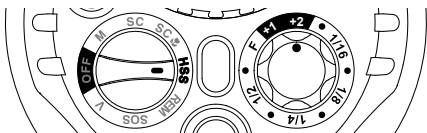

Note: The HSS mode is only intended for use with 3rd party flash triggers that support HSS firing for non-Olympus cameras or with the Backscatter Sony TTL Flash trigger set to manual flash mode. To use HSS with Olympus cameras, please follow the instructions for using Super FP in SC mode. (page 18)

Note: HSS reduces flash output compared to regular shooting. Only use it for close-up shooting. The flash will diminish the faster the shutter speed is set. The Hybrid Flash has one output power in HSS mode. Changing the shutter speed to dial in the flash exposure is the recommended method for altering the flash exposure in the image.

Settings for HSS on Non-Olympus Mirrorless and SLR Cameras:

1. Turn the mode dial on the Hybrid Flash to HSS.
2. Set the flash trigger to the appropriate HSS setting for use with the Hybrid Flash. Follow the flash trigger manufacturer's instructions for HSS compatibility and proper settings.

Camera Settings for HSS with Sony Mirrorless Cameras in HSS Mode with the Backscatter Sony TTL Flash Trigger

1. Turn the mode dial on the Hybrid Flash to HSS.
2. Go to Camera Menu → Flash → set Wireless Flash to ON.
3. Go to Camera Menu → Shutter/Silent → Shutter Type → set to Mechanical Shutter.

Additionally for Cameras with e-Front Curtain Shutter:

4. Go to Camera Menu → Shutter/Silent → e-Front Curtain Shut. → set to Off (if available).

Note: For HSS use, Sony cameras must have the Shutter type be mechanical and e-front curtain shutter (if offered as an option) must be off. If these menu settings are not made banding may appear in the image, which will worsen with faster shutter speeds. This setting is not specific to the Hybrid Flash, this is for any Sony camera being used with a HSS compatible flash. Please see your Sony camera instruction manual for more details.

Note: On the camera, the switch from normal operation to HSS is automatically handled by the flash trigger when the camera's shutter speed is set faster than the flash sync speed limit. The camera will indicate it is in HSS mode when the flash icon changes from a single lighting bolt flash icon to having HSS displayed next to the flash icon.

Note: The Hybrid Flash must be set in HSS mode to fire when Wireless Flash is set to ON. It will not fire in SC mode when the flash trigger is set to manual operation (Wireless Flash ON).

Pro Tip: If you primarily shoot in Manual flash mode (rather than TTL in SC mode) it is recommended to use the HSS mode (rather than SC mode) on the Hybrid Flash to do HSS as the only required change to shoot in HSS is to move the Hybrid Flash mode dial to HSS. This makes it faster to switch between normal shooting and HSS shooting.

For using HSS while in SC mode (TTL), please see the section titled "Camera Settings for HSS with Sony Mirrorless Cameras in SC Mode with the Backscatter Sony TTL Flash Trigger." (page 18)

MODE REMOTE LIGHTING CONTROL (REM)

The Hybrid Flash's Remote Lighting System allows the use of a camera-mounted Hybrid Flash to wirelessly trigger and change the brightness of a remotely placed Hybrid Flash or Backscatter Mini Flash 2. This is a great way to achieve side lighting, backlighting, or remote snooting on a tripod or Backscatter Remote Lighting Muck Stick without having to reach the remote flash to change power levels. It provides the freedom to frame shots completely untethered. The Hybrid Flash can also be mixed and matched with the Backscatter Mini Flash 2 for remote operation.

A minimum of two strobes are required for remote operation. The camera-mounted flash is the "main" flash connected to the camera by a fiber optic cable that will send the power level control signal and trigger the "remote" flash or flashes. The remote flash requires the installation of the included Light Pipe for wireless operation.

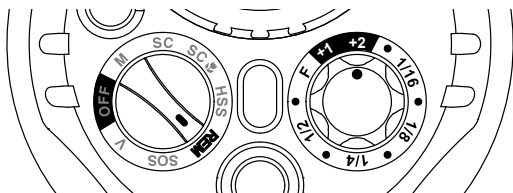

Note: It is possible to use a Mini Flash 2 as a main flash to send signals to a Hybrid Flash or to receive signals from a remote strobe from a Hybrid Flash. Since there are only 7 power levels on a Mini Flash 2 and 12 power levels on a Hybrid Flash, only the top 7 power levels will be able to be used in remote operation when combining a Mini Flash 2 with a Hybrid Flash.

Note: Use the optional IR filter to block any visible light from the main triggering strobe from showing up in the image.

Set Up and Install the Light Pipe on the Remote Flash

1. Stretch the rubber lanyard of the Light Pipe over the 1-inch ball mount
2. Press and thread the Light Pipe into the remote Hybrid Flash fiber optic socket.
3. Set the mode dial to Remote (REM).
4. Attach Hybrid Flash to the Backscatter Remote Lighting Muck Stick or tripod and aim at the subject.
5. Rotate the Light Pipe to aim directly at the main flash.

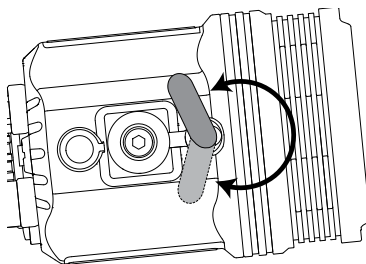
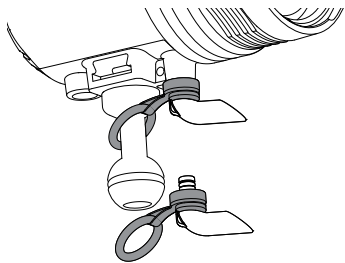

Note: The Light Pipe rubber lanyard is only compatible with the 1-inch ball mount, not a YS mount.

Set Up the Main Flash On Camera

1. Connect the main Hybrid Flash to your camera system with a fiber optic cable.
2. Set the Mode Dial to Manual (M).
3. Aim the main strobe toward the remote Light Pipe of the remote strobe.

MODE REMOTE LIGHTING CONTROL (REM) (CONT.)

Use the Test Button to Send Power Level Changes Wirelessly

1. Make sure the main flash and the Light Pipe of the remote flash are facing each other and are within line of sight.
2. To send a flash power level setting from the main flash to the remote flash, set the desired power level on the main flash's Red dial, then press and hold the Test button. You will see a series of light signals from the main flash, and the remote flash will fire immediately. A confirmation flash from the remote flash about a second later will indicate that the remote flash has received the power level signal.
3. Once the main power level signal has been set, the remote flash will stay at that power level until a new power level signal is sent.
4. When taking a picture, the main flash will trigger the remote flash. This allows the freedom to use the main flash for front lighting at any power level desired while maintaining a different power level setting for the remote flash.

CONTROL YOUR SECOND STROBE WIRELESSLY:

Press the silver button to beam a new power level to your off-camera wireless second Hybrid Flash. Rotate the light pipe to make any position work.

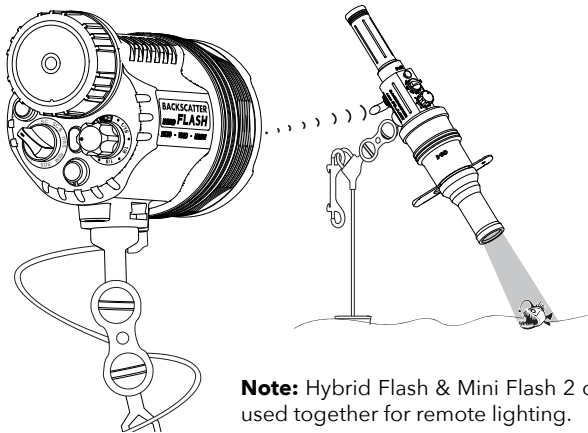

Note: Hybrid Flash & Mini Flash 2 can be used together for remote lighting.

MODE SOS

SOS will put the LED lights in Beacon mode (1 flash every 3 seconds). A long press on the Mode button will activate Alert mode, which is a rapid firing of the LED light. Release the Mode button to return to Beacon mode.

The flash is not active in SOS mode.

MODE VIDEO (V)

Video mode enables the full 5000-lumen output of the wide mode LEDs in 3 power levels. To change power levels, short press the silver button to toggle between High, Medium, Low, and OFF.

The flash is not active in Video mode.

Note: When switching from Video Mode to one of the photo modes, the time for the flash to charge to full power may be longer for the first shot after switching from Video to a Photo Mode.

TEST BUTTON

The TEST button allows the Hybrid Flash to be fired at any desired power output with the press of the TEST button. This is a great way to do light painting with long exposures instead of a video light, do a long exposure, and fire the flash multiple times on a subject for a “stroboscopic” effect, or it can be used as a signaling device in case of emergency.

INDICATOR LIGHT CHART

Please review the chart below for the indicator lights and description.

Main Indicator Color	Signal Pattern	Description
Blue	Quick Blinking	Flash Charging
Blue	Slow Blinking	Flash Charging, ready for flash within 1/2 stop of full power
Green	Solid On	Flash Ready with battery level 100 to 50%
Yellow	Solid On	Flash Ready with battery level 50 to 25%
Red	Solid On	Flash Ready with battery level 25 to 10%
Red	Blinking (1 sec period)	Battery level 10 to 1% Flash is not charging. Focus Light & Video Light are dimmed.
Green	Slow Blinking (2 sec period)	Stand-by Mode with battery level 100 to 50%
Yellow	Slow Blinking (2 sec period)	Stand-by Mode with battery level 50 to 25%
Red	Slow Blinking (2 sec period)	Stand-by Mode with battery level 25 to 1%
Purple	Blinking with 3 rapid beeps	TTL out of exposure range in SC mode.
Purple	Blinking with 1 long beep	Enter temperature protection mode, flash power reduced.
Purple	Solid On	Temperature protection mode where flashing is paused for 2 minutes.
Red	Quick Blinking for 2 sec & power off	Battery Extremely Low & auto-off.
Purple	Continually Blinking	Circuit error (contact Backscatter for support)

Test Indicator Color	Signal Pattern	Description
Blue	Solid On	Olympus/OM TTL in SC modes
White	Solid On	Sony TTL in SC modes

BATTERY FAQ LITHIUM ION (LI-ION)

BATTERIES TO USE WITH THE HYBRID FLASH

A catastrophic battery accident can result in fire, explosion, injury, and death, even when all precautions have been taken. Please read the following FAQ about battery usage and safety precautions to minimize that risk.

What batteries should I use for the Backscatter Hybrid Flash?

At this time we only recommend the Nitecore 21700 NL2153HP 5300mAh Li-Ion for use with the Backscatter Hybrid Flash. The Hybrid Flash was developed with this battery in mind and, thus, the only one we officially recommend for the safety and proper performance of the Hybrid Flash. All performance specifications were tested with this battery.

This battery has a high performance current draw of 20A that is necessary for the Hybrid Flash to operate. Using a battery with a current of lower than 15A will cause the Hybrid Flash to shut down the battery.

Where can I purchase a Nitecore 21700 NL2153HP 5300mAh Li-Ion battery?

Since it is a standard battery type, Nitecore 21700 NL2153HP 5300mAh Li-Ion batteries are available at Backscatter, Backscatter Authorized Dealers, and many other retailers worldwide.

I see other 21700 batteries all over the internet selling for super cheap that are like \$5, why can't I use those? Are you guys trying to rip me off?

Those cheap batteries are unprotected and not designed for end use by consumers, and do not have important safety protections built in. They can sometimes be identified by having no branding on the label or by a plain single-color battery jacket with dot matrix printing. Unprotected batteries without safety protections are much cheaper to produce than batteries with protection circuitry. The Nitecore 21700 NL2153HP 5300mAh Li-Ion battery is the only approved battery for the Hybrid Flash.

What is the difference between a “protected” battery and an “unprotected” battery, and why should I always use a protected battery?

Protected Lithium-Ion batteries have an electronic circuit built into the battery cell packaging. This circuit protects the battery against overcharge, over-discharge, short circuit, over-current, and extreme temperature fluctuations. Protected batteries are safer to use than unprotected batteries that do not have these safety features built in. Unprotected batteries have no built-in safety protections, which can result in fire, explosion, injury, or death in the case of failure due to overcharge, over-discharge, short circuit, over-current, or temperature, even when every precaution has been taken. Unprotected 21700 batteries are not designed for consumer use, so do not use it. Only use protected batteries designed for consumer use.

Why are unprotected batteries sold if there are greater safety risks versus a protected battery?

21700 batteries are a very common and popular Li-Ion battery not only made for end-use consumers but also used by manufacturers to combine multiple units into a larger battery pack for anything from flashlights to electric cars. Did you know Tesla electric cars are running on battery packs made up of thousands of 21700 batteries? It is up to those manufacturers to build in their own safety precautions for their custom-designed battery packs.

Why should I always charge the battery in a common area when people are around?

Although battery failures are rare, it can be catastrophic. The charging process is a critical operation. Most Li-Ion battery failures that occur happen during charging. Never charge in sleeping quarters, below boat decks, or in other unmonitored or unoccupied areas. In case of emergency, you want someone around to be able to take action. While it is rare for a battery to fail when all proper safety precautions have been taken, the consequences are too great to ignore.

How do I store batteries when not in use?

Batteries should be stored in a battery storage box explicitly designed for 21700 batteries. A proper box will provide impact protection and keep batteries isolated so the battery contacts cannot be bridged and cause a short.

What do I do if a battery has physical damage or water damage?

Immediately stop using the battery, as it is now a safety hazard. Immediate action needs to be taken to dispose of the battery safely. If at home, take it immediately to an authorized battery recycling center or hazardous materials disposal site. If at a resort or a live aboard boat, notify resort management or the boat captain immediately so that they may safely dispose of the battery. If on land and unable to take it to an authorized battery recycling center, place it in a fireproof box and store it outside in an open area away from any sources of fuel or ignition until a time when the damaged battery can be taken to an authorized battery recycling center. Never dispose of batteries in the garbage or trash.

I suspect water has intruded the battery compartment and/or strobe. What should I do?

Immediately discontinue using the Hybrid Flash and remove the batteries as soon as practically possible. Even though the Hybrid Flash has an over-pressure relief valve in case of overpressure, take extra precautions when opening the battery compartment, as it may be over-pressurized. Use a damp towel to cover the Hybrid Flash before opening to protect yourself and others.

If I have water intrusion into the battery compartment, can I dry it out and use new batteries?

Maybe. The battery compartment is sealed from the rest of the flash for safety. After water intrusion, rinse the battery cap and battery compartment of the Hybrid Flash with fresh water. When the battery cap and contacts are completely dried and cleaned free of corrosion, then new batteries may be installed and the Hybrid Flash tested for operation. However, if there is any unusual operation of the Hybrid Flash with the new batteries, immediately discontinue use, remove the batteries, and contact the Backscatter service department or your local Backscatter dealer.

Can I leave the battery installed in the Hybrid Flash for travel?

NEVER travel with the battery installed in the Hybrid Flash.

Can I travel with the batteries in my checked luggage?

Absolutely not. It is illegal to travel with Li-Ion batteries in the cargo hold on passenger aircraft. All Li-Ion batteries must be carried on aircraft in cabin luggage in an appropriate battery box that does not allow the battery contacts to be bridged.

Never fly with damaged batteries. Damaged batteries are banned from ALL aircraft by law for good reason. **Do not take chances. Your life and the lives of others are not worth a cheap battery!! Dispose of damaged batteries immediately!!**

All this battery safety talk has me concerned.

You should be. Following these procedures and precautions can help minimize risk greatly, but there is no way to completely eliminate it. While battery failures that cause catastrophic damage, injury, and death are very rare, it is your responsibility to use the best care possible to minimize that risk to yourself and others.

Safety precautions need to be taken with Li-ion batteries.

Never do the following:

- Never charge batteries in unattended areas.
- Never charge while sleeping.
- Never charge below decks of a boat.
- Never store batteries below decks of a boat.
- Never store batteries in the Hybrid Flash below decks of a boat.
- Never use batteries without protection circuitry.
- Never dispose of batteries in the garbage or trash.
- Never put batteries in checked baggage when traveling.
- Never walk around with bare batteries in your pocket, especially with other metal objects that can easily bridge battery contacts.

Always do the following:

- Only charge batteries in common areas where and when others are around.
- Always remove the battery from the Hybrid Flash when not in use.
- Only use batteries designed for end use by consumers with safety protection circuitry.
- Only store batteries in a battery box designed for 21700 batteries.
- Always travel with batteries in cabin baggage.

***ALWAYS OBEY ALL INSTRUCTIONS
FROM THE BATTERY MANUFACTURER***

SPECIFICATIONS:

Depth Rating: 100m/330ft

Guide Number: *f*40

Maximum LED Output: 5,000 Lumens

Power: Two 21700 Nitecore NL2153HP 5300mAh Batteries

Recycle time:

+2: 1.6 - 2.17 seconds

+1: 0.7 - 1.17 seconds

F: 0.5 - 0.86 seconds

Number of Flashes:

+2: over 375

+1: over 800

F: over 1,000

LED Run Time: Minimum of 90 minutes with managed power decline curve

Emergency Ping Run Time: ~27 hours with full battery

Weight in Air: 2.5lbs / 1.14kg (with battery)

Weight in Water: 8.8oz / 250g (with battery)

Sync Cord: Fiber Optic

Seal: Dual O-Rings with additional Sand Seal Gasket

Exposure Control:

Flash: 12-step Power Level

LED: 3-step Power Level

Dimensions With Ball (LxWxD):

6.34 x 3.70 x 6.38in

161 x 94 x 162mm

Material: Anodized Machined Aluminum and Glass Fill Fiber

International Patents Pending

BACKSCATTER **HYBRID FLASH**

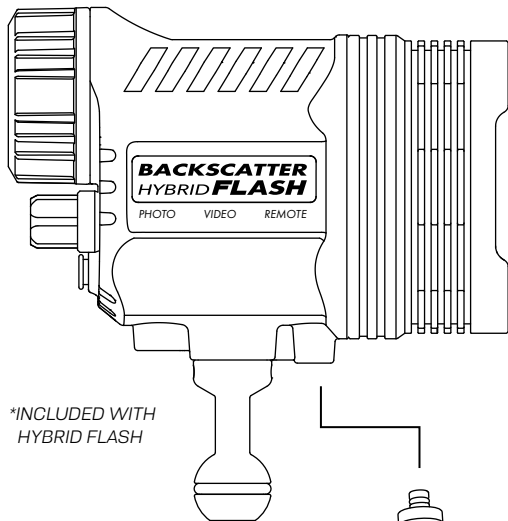

**INCLUDED WITH
HYBRID FLASH*



*LIGHT PIPE**

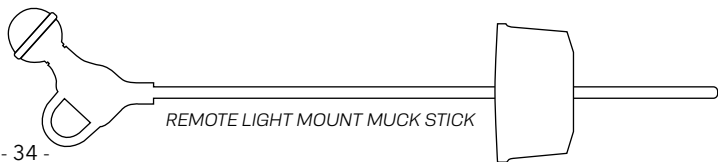

REMOTE LIGHT MOUNT MUCK STICK

SYSTEM CHART



WHITE
140° FLAT
DIFFUSER*



WHITE
160° DOME
DIFFUSER



REMOTE IR
FILTER



AMBIENT
140° FLAT
DIFFUSER



AMBIENT
160° DOME
DIFFUSER



5500K
140° FLAT
DIFFUSER



5500K
160° DOME
DIFFUSER



4500K
140° FLAT
DIFFUSER



4500K
160° DOME
DIFFUSER

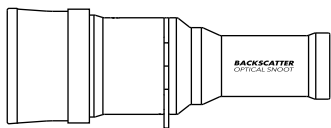

OPTICAL SNOOT

DISTRIBUTED BY:

BACKSCATTER
UNDERWATER VIDEO & PHOTO

225 Cannery Row, Monterey, CA. 93940
+1-831-645-1082
sales@backscatter.com
www.backscatter.com

For any support or service questions on your Hybrid Flash, please give us a call or send us an email!

DOWNLOAD
INSTRUCTIONAL
VIDEO



BACKSCATTER.COM/HF-1-SUPPORT